

LNF - 64/60
16 Novembre 1964.

G. Barbiellini, G. Bologna, J. DeWire, G. Diambri, G. P. Murtas
and G. Sette: MEASUREMENT OF THE REACTION $\gamma + p \rightarrow p + \pi^0$
NEAR THE FIRST RESONANCE FROM THE POLARIZED PHO-
TONS OF THE FRASCATI 1 GeV COHERENT BREMSSTRAHLUNG
BEAM.

(Nota interna : n. 266)

Nota interna: n° 266
16 Novembre 1964

G. Barbiellini, G. Bologna, J. De Wire^(x), G. Diambri⁽⁺⁾, G. P. Murtas, and G. Sette. : MEASUREMENT OF THE REACTION $\gamma + p \rightarrow p + \pi^0$ NEAR THE FIRST RESONANCE FROM THE POLARIZED PHOTONS OF THE FRASCATI 1 GeV COHERENT BREMSSTRAHLUNG BEAM.

Linearly polarized bremsstrahlung has been already used by Drickey and Mozley⁽¹⁾ to study π^0 photoproduction at low energy. They used a small cone of the γ -ray beam of the Stanford linear accelerator from an ordinary radiator.

A coherent bremsstrahlung beam^(2,3) produced by using a crystal (diamond) radiator in the 1 GeV Frascati electronsynchrotron is now available for experiments with linearly polarized photons. This beam has two essential characteristics first of all, its energy spectrum has some peaks which are movable along the spectrum by changing the angle θ between the electron beam and a crystal axis. Thus one can fix the position of a peak so as to obtain the largest number of useful photons in the required energy range. Further, one of the peaks is strongly linearly polarized over the whole bremsstrahlung cone. Plots of the calculated energy spectrum and its polarization together with experimental results were already published^(2,3).

We used this γ ray beam in order to study the reaction

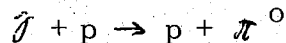

We measured the ratio $d\sigma_{\perp}/d\sigma_{\parallel}$ at two different photon energies $K_1=325$ MeV and $K_2=228$ MeV; $d\sigma_{\perp}$, $d\sigma_{\parallel}$ are the differential cross sections from photons with polarization perpendicular or parallel to the reaction plane respectively.

(x) - Now at Cornell University, Ithaca, N. Y. (U. S. A.).

(+) - Now at Istituto di Fisica dell'Università and Sezione I. N. F. N. di Genova.

2.

Fig. 1 shows up-to-date results for the coherent bremsstrahlung from a diamond crystal, which we used for the $K_1 = 325$ MeV measurement. The abscissa is the fractional energy $x = k/E_1$ of the photons with respect to the primary electrons. The lower curve represents, in arbitrary units, the calculated bremsstrahlung intensity $I(x, \theta)$, i. e., a quantity which is proportional to the number $kn(k)$, where $n(k)dk$ is the number of photons of the entire bremsstrahlung cone, whose energy is between k and $k+dk$. The upper curve represents the polarization

$$(1) \quad P(x, \theta) = \frac{N_t - N_p}{N_t + N_p} ;$$

N_t and N_p are the number of photons of the entire beam with polarization perpendicular and parallel, respectively, to the plane determined by the momentum \vec{p}_1 of the incoming electron and the crystal axis $[110]$. The angle between \vec{p}_1 and the axis $[110]$ is $\theta = 1^\circ 10'$. The axis $[001]$ is supposed to be in the plane determined by p_1 and $[110]$. The electron energy is 1000 MeV. The two curves are corrected for the finite energy resolution of the pair spectrometer used to measure the spectrum⁽²⁾. No correction was made for the multiple scattering of the electrons in the diamond radiator (which is a slab 2 mm thick, cut perpendicular to the axis $[110]$), nor for the finite collimation of the γ -ray beam and for the finite size and angular divergence of the electron beam.

The crosses and the circles in Fig. 1 represent, in arbitrary units, the measured number of electron pairs created in the pair Spectrometer Aluminium target (0, 1 mm thick) per constant number of monitor units, obtained with the plane of the axes $[110]$ and $[001]$ horizontal and vertical, respectively. The γ -ray beam collimation was 1.5 mrad. The statistical error is of the order of the size of the crosses and circles.

In Fig. 2 the lower curve represents the ratio $I(\theta, 0.333)/I(\theta, 0.850)$ of the bremsstrahlung intensities at $x = 0.333$ and $x = 0.850$, as a function of $\theta = \angle(p_1, [110])$, the axis $[001]$ being in the plane of \vec{p}_1 and $[110]$. The upper curve represent the polarization for $x = 0.333$. These curves include the correction for the pair spectrometer energy resolution, for the variation of the pair production cross section and, in a provisional way, for the multiple scattering of the primary electrons in the diamond and for the finite collimation of the γ -ray beam.

The crosses and the circles represent the experimental results obtained with the plane of the axes $[110]$ and $[001]$ horizontal and vertical respectively. In the former case we change θ by rotating the crystal around a vertical axis, in the latter case we rotate it around a horizontal axis. In these two measurements only the direction of the polarization is changed and is vertical or horizontal respectively. The measurements were made with a γ -ray beam collimation of 1.5 mrad. The statistical error is of the order of the size of the crosses and circles.

These and other measurements have to be done before using the γ -ray

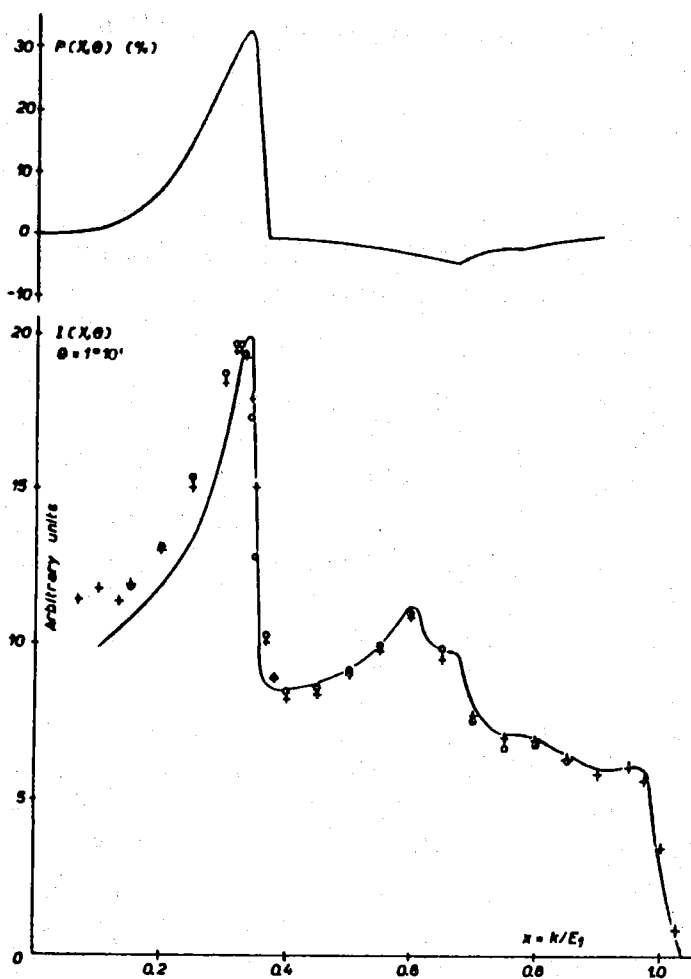

FIG. 1

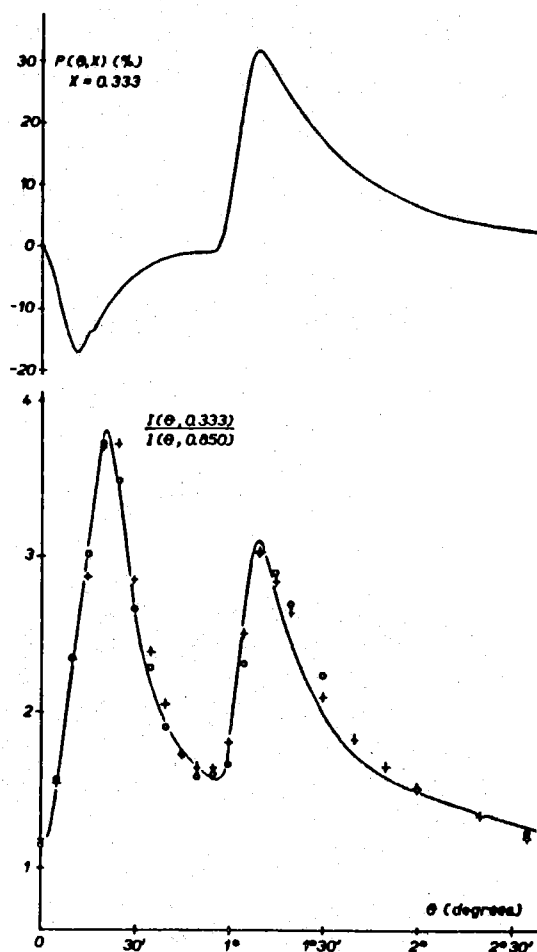

FIG. 2

FIG. 1 - Coherent bremsstrahlung intensity $I(x, \theta)$ and its polarization $P(x, \theta)$ as a function of the fractional energy $x = k/E_1$ of the photons. The diamond crystal is at room temperature, with the axis $[110]$ at the angle $\theta = 1^\circ 10'$ with respect to the direction of the primary electron. The axis $[001]$ lies in the plane determined by the primary electron and the axis $[110]$. The electron energy is $E_1 = 1000$ MeV. The lower curve gives, in arbitrary units, the calculated bremsstrahlung intensity $I(x, \theta)$, which is proportional to $kn(k)$, $n(k)dk$ being the number of photons of energy spread dk at k . The upper curve gives the polarization $P(x, \theta)$. The curves are corrected for the pair spectrometer resolution and for the variation of the pair production cross section in the converter. The crosses and the circles represent the experimental results, obtained with the plane of the axes $[110]$ and $[001]$ horizontal and vertical, respectively. The γ -ray beam collimation was 1.5 mrad. The statistical error is of the order of the size of the crosses and circles.

FIG. 2 - Same conditions as in Fig. 1. The abscissa is the angle θ , between the electron direction and the crystal axis $[110]$. The lower curve represents the ratio of the bremsstrahlung intensities at $x=0.333$ and $x=0.850$. The upper curve represent the polarization for $x=0.333$. The curves are corrected for the pair spectrometer energy resolution.

for multiple scattering in the diamond radiator, and for the finite collimation of the γ -ray beam. The crosses and the circles represent the experimental results obtained with the plane of the axes $[110]$ and $[001]$ horizontal (the polarization is vertical) and vertical (the polarization is horizontal) respectively. The collimation of the γ -ray beam is 1.5 mrad.

4.

beam in the π^0 experiment, in order to verify the proper positioning of the crystal.

Consider now the process

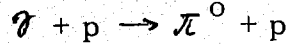

from linearly polarized photons. As is well known, in the region of the first resonance and below, where presumably only S and P waves contribute, the differential cross section per unit solid angle in the center-of-mass system can be written:

$$(2) \quad \frac{d\sigma}{d\Omega^*} = A + B \cos^2 \theta^x + C \cos^2 \theta^x + \alpha \sin^2 \theta^x \cos^2 \psi,$$

where θ^x is the center-of-mass emission angle of the π^0 , and ψ is the angle between the polarization plane (i. e., the plane determined by the direction of the incoming photon and the direction of its polarization) and the production plane (i. e., the plane determined by the photon and the emitted pion). A, B, C, α are dependent on the photon energy, and we have calculated their values from the C. G. L. N. theory⁽⁴⁾.

Our measurements consist in the determination of the number of neutral pions produced in liquid hydrogen at $\theta^x = 90^\circ$, from photons having polarization both perpendicular and parallel to the emission plane. In the first experiment the nominal energy of the photons is fixed at $K_1 = 325$ MeV. In these conditions the π^0 is emitted in the laboratory system at $\theta = 73^\circ$ and the proton at $\theta_p = 40.5^\circ$, with a kinetic energy of $T_p = 61$ MeV. The corresponding values for the second measurement at $K_2 = 226$ MeV are $\theta_{\pi} = 74^\circ$, $\theta_p = 35.6^\circ$, $T_p = 28.5$ MeV.

The detection apparatus is conventional and is sketched in Fig. 3. It consists of a range telescope T (which includes the scintillators S_1 , S_2 , S_3 and the aluminium absorbers A_1 , A_2 , A_3 and the wedge-shaped one), an integral Cerenkov counter C for the detection of the π^0 -decay photons and a scintillator A, set in front of C, in order to discriminate against charged particles traversing C. In the actual arrangement the nominal production plane of the π^0 is horizontal.

A telescope event is defined by the anticoincidence

$$T = (S_1 + S_2) - (S_1 + S_2 + S_3)$$

where $S_1 + S_2$ and $S_1 + S_2 + S_3$ are coincidences among the telescope scintillators. This anticoincidence has a resolving time of 6 nsec. Further we consider the anticoincidence

$$Q = (T + C) - (T + C + A),$$

where $T + C$ and $T + C + A$ are coincidences between the telescope T and the Cerenkov counter C, and among T, C and the scintillator A, respectively. The anticoincidence Q opens a linear gate circuit through which the pulses coming from the scintillator S_1 are passed. The pulses coming from the gate circuit are sent to a 200-channel pulse height analyzer, by means of which we discri

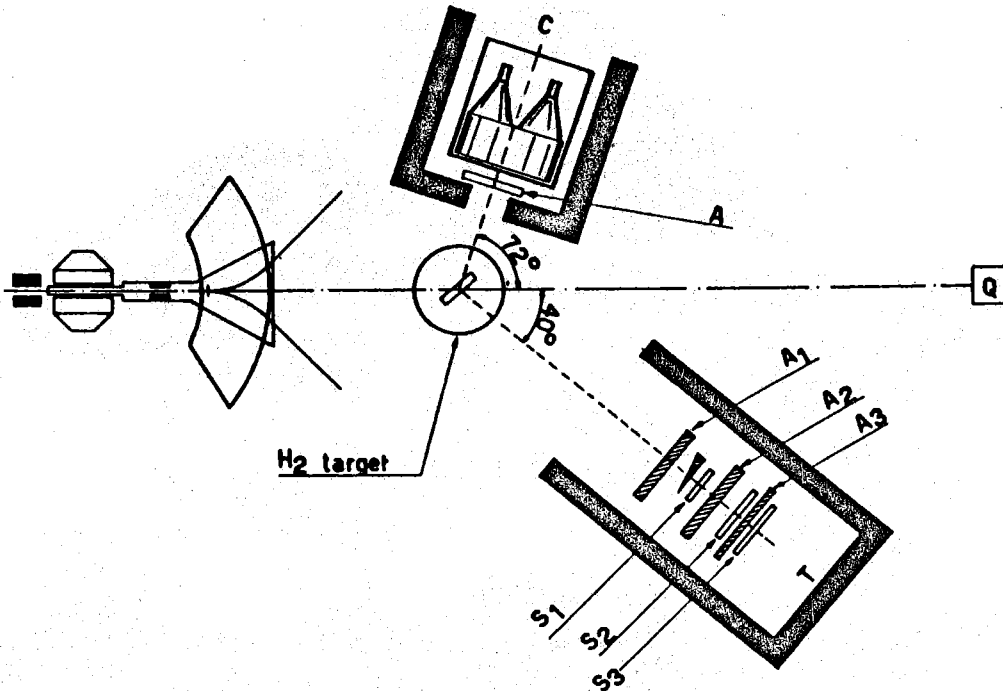

FIG. 3 - Sketch of the experimental apparatus.

minate between protons and other charged particles by a dE/dx method. The protons detected in this way represent the π^0 photoproduction events.

Two sets of measurements were performed, corresponding to the two chosen directions of the polarization (horizontal and vertical) previously described. In each set the number of π^0 mesons was measured as a function of the angle θ between the electron beam and the axis $[110]$. By changing θ the photon peak is allowed to move along the spectrum (its height decreases by increasing θ). In this way one obtains a result similar to an excitation curve for the π^0 's.

We define the counting rates

$$Y_{\parallel} = \frac{N_{\parallel}(p)}{N_0}, \quad Y_{\perp} = \frac{N_{\perp}(p)}{N_0},$$

where $N_{\parallel}(p)$ and $N_{\perp}(p)$ are the number of π^0 mesons produced from photons having polarization parallel and perpendicular to the (horizontal) production plane, respectively. N_0 is the number of 850 MeV photons, measured simultaneously with $N_{\parallel}(p)$ or $N_{\perp}(p)$ by means of the pair spectrometer (see on the left of Fig. 3). At an incident electron energy of 1000 MeV the coherence effect is small for 850 MeV photons, making N_0 nearly independent of θ . Thus N_0 is a suitable monitor.

The counting rates are given by

$$(3) \quad \begin{aligned} Y_{\parallel} &= \mathcal{F} \frac{N}{N_0} \frac{d\mathcal{G}_0}{d\Omega} \left[1 - \frac{1}{2} RP \right] \\ Y_{\perp} &= \mathcal{F} \frac{N}{N_0} \frac{d\mathcal{G}_0}{d\Omega} \left[1 + \frac{1}{2} RP \right] \end{aligned}$$

where \mathcal{P} is a constant; $N = N_t + N_p$ is the number of photons giving rise to the reaction; N_0 was already defined; P is the polarization of the photons, given by equation (1); $d\sigma_0/d\Omega$ is the π^0 photoproduction cross section from unpolarized photons per unit solid angle in the laboratory system, i. e. ,

$$\frac{d\sigma}{d\Omega} = \frac{1}{2} \left[\frac{d\sigma_{\parallel}}{d\Omega^*} + \frac{d\sigma_{\perp}}{d\Omega^*} \right] \frac{d\Omega^*}{d\Omega}$$

where $d\sigma_{\parallel}/d\Omega^*$ and $d\sigma_{\perp}/d\Omega^*$ are the differential cross sections per unit solid angle in the center-of-mass system for π^0 emitted in the plane parallel and perpendicular to the photon polarization and given by equation (2) for $\psi = 0$ or $\psi = 90^\circ$, respectively. Finally in equations (3) we have

$$R = \frac{d\sigma_{\perp} - d\sigma_{\parallel}}{d\sigma_0}$$

As we already said, we have chosen $\theta^x = 90^\circ$; thus we obtain from equation (2)

$$\frac{d\sigma_0}{d\Omega^*} = A \quad ; \quad R = - \frac{2\alpha}{A}$$

At a photon energy $K_1 = 325$ MeV we assumed $\alpha = C$ as justified from C. G. L. N. theory and evaluated A and C from this theory. For instance, at $K_1 = 325$ MeV we obtained⁽⁵⁾ $A = 26.6 \mu$ barn/sterad. and $C = -15.7 \mu$ barn/sterad. Further we evaluated the quantities N , N_0 and P as a function of the angle θ between the γ -ray beam and the crystal axis $[110]$ in our experimental conditions, which are: $E_1 = 1000$ MeV for the electron energy; $K_1 = 325$ MeV for the photon energy; $K_0 = 850$ MeV for the monitor photon energy; direction of the electron beam parallel to the crystal axes $[110]$ $[001]$. N_0 , N and P are corrected, in a provisional way, for the multiple scattering of the electrons in the diamond radiator and for the finite collimation of the γ -ray beam. In the calculation of the counting rates, we integrated equations (3) over the photon energy acceptance in order to correct for the finite photon energy resolution.

In Fig. 4 the results for a photon energy of $K_1 = 325$ MeV are shown. The continuous and the dashed curves represent, in arbitrary units, respectively Y_{\perp} and Y_{\parallel} , as given by equations (3). The two curves are coincident in the neighborhood of $\theta = 50^\circ$ and at large θ , where the polarization is nearly vanishing. In the last peak ($\theta = 1^\circ 07'$) Y_{\parallel} is lower than Y_{\perp} ; the contrary happens for the first peak as the polarization reverses its sign (see Fig. 2). The experimental values of Y_{\perp} and Y_{\parallel} are given by the crosses and the circles, respectively, and were obtained with a collimation of 1.5 mrad. The errors quoted are statistical. A systematic error comes from proton Compton effect; presumably this contribution is of the order of 1%.

The measurements with the highest statistics were made at $\theta = 1^\circ 10'$, where the polarization has about the largest value. At $\theta = 1^\circ 10'$ we obtained

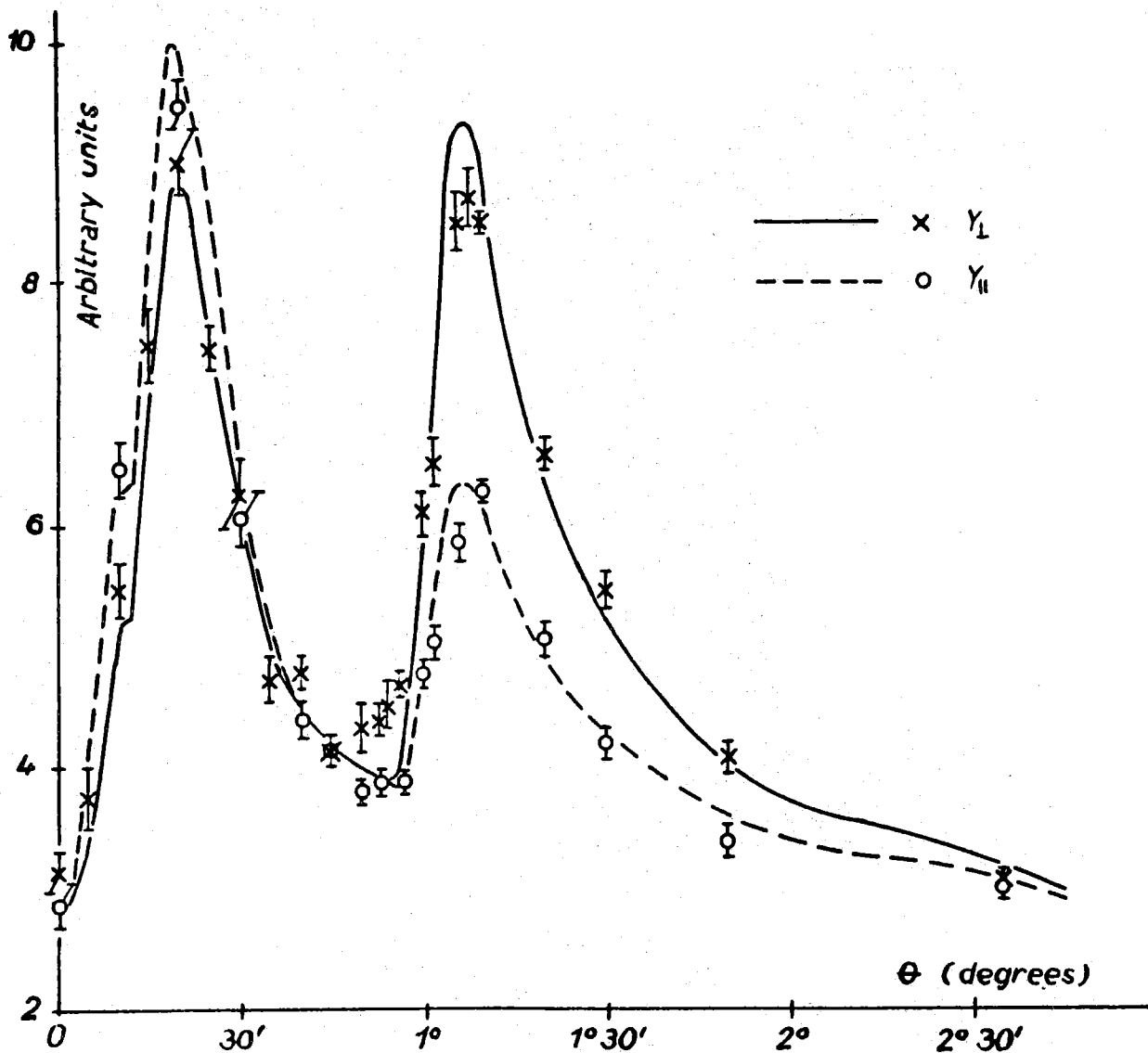

FIG. 4 - The abscissa is the angle θ in degrees. The ordinate is the π^0 counting rate. The continuous and the dashed curve represent, in arbitrary units, Y_{\perp} and Y_{\parallel} , respectively, as given by equations (3), and corrected for the finite photon energy resolution. The points and the crosses represent the experimental values of Y_{\perp} and Y_{\parallel} respectively, obtained with a collimation of 1.5 mrad. All these data are relative to π^0 mesons emitted at $\theta^* = 90^{\circ}$ in the center-of-mass system and produced from 325 MeV photons.

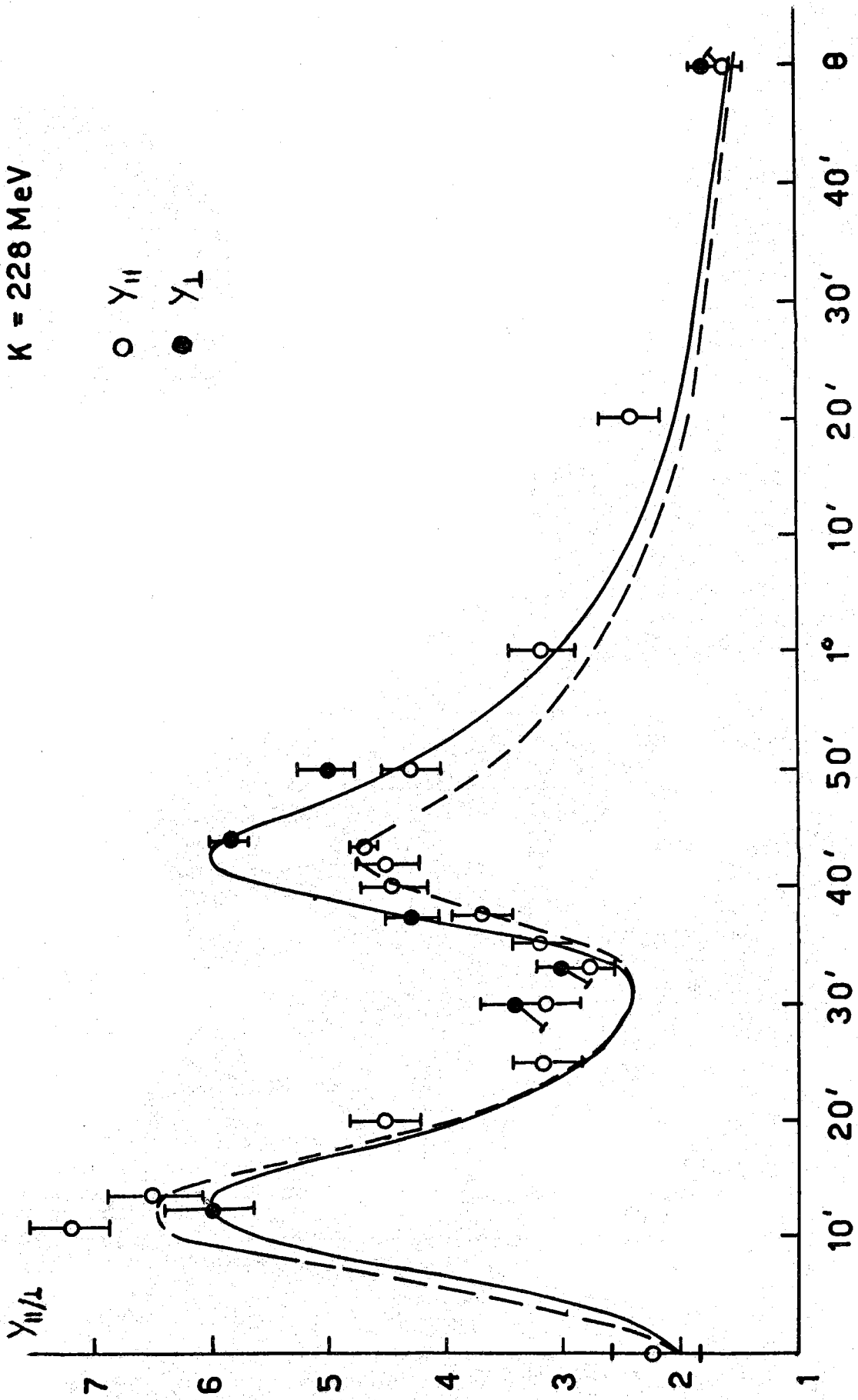

FIG. 5

$$\left. \begin{array}{l} \frac{Y_{\perp}}{Y_{\parallel}} = 1.37 \pm 0.01 \\ P = 30.6\% \end{array} \right\} \begin{array}{l} \text{(Experimental)} \\ \text{(Calculated)} \end{array} \quad K_1 = 325 \text{ MeV}$$

Thus we have, for $\theta^x = 90^\circ$

$$\frac{\alpha}{A} = \frac{1 - (d\sigma_{\perp}/d\sigma_{\parallel})}{1 + (d\sigma_{\perp}/d\sigma_{\parallel})} = \frac{1}{P} \frac{1 - (Y_{\perp}/Y_{\parallel})}{1 + (Y_{\perp}/Y_{\parallel})} = 0.51 \pm 0.01.$$

Further we obtain

$$\frac{d\sigma_{\perp}}{d\sigma_{\parallel}} = \frac{A - \alpha}{A + \alpha} = 3.1 \pm 0.1.$$

The measurements at the photon energy $K_2 = 228 \text{ MeV}$ followed, exactly the same way. The results are plotted in fig. 5. We obtained for the counting ratio at $\theta = 43.5'$

$$\frac{Y_{\perp}}{Y_{\parallel}} = 1.20 \pm 0.014.$$

In order to obtain the ratio

$$\frac{\alpha}{A} = \frac{Y_{\parallel} - Y_{\perp}}{Y_{\perp} + Y_{\parallel}} \frac{1}{P} = 0.246 \pm 0.016 \quad P = 0.37$$

one has to calculate carefully the exact value of the polarization P averaged over all the experimental resolutions. At this energy of the photons it is a little expensive in time to take into account the influence of the multiple scattering on the P value as accurately as in the previous measurement, because of the smaller angles involved in the crystal. With a good fiducial level P has been estimated equal to 37%.

Better calculation is in progress and we hope it will be soon ready.

REFERENCES.

- (1) - D. J. Drickey and R. F. Mozley, Phys. Rev. Letters 8, 291 (1962).
- (2) - G. Barbiellini, G. Bologna, G. Diambri, G. P. Murtas, Phys. Rev. Letters 8, 454 (1962).
- (3) - G. Barbiellini, G. Bologna, G. Diambri, G. P. Murtas, Phys. Rev. Letters 9, 396 (1962).
- (4) - G. F. Chew, M. L. Goldberger, E. F. Low and Y. Nambu, Phys. Rev. 106, 134 (1957).
- (5) - J. De Wire, Laboratori Nazionali di Frascati, Internal Report LNF-61/39 (1961) (unpublished).